

D. S. Bernstein

S. P. Bhat<sup>1</sup>

Department of Aerospace Engineering,  
The University of Michigan,  
Ann Arbor, MI 48109-2118

# Lyapunov Stability, Semistability, and Asymptotic Stability of Matrix Second-Order Systems

*Necessary and sufficient conditions for Lyapunov stability, semistability and asymptotic stability of matrix second-order systems are given in terms of the coefficient matrices. Necessary and sufficient conditions for Lyapunov stability and instability in the absence of viscous damping are also given. These are used to derive several known stability and instability criteria as well as a few new ones. In addition, examples are given to illustrate the stability conditions.*

## 1 Introduction

The stability of matrix second-order systems has been of considerable interest for over three decades (Duffin, 1955; Lancaster, 1966). These systems, which are of the form  $M\ddot{x} + (C + G)\dot{x} + Kx = 0$ , are of fundamental importance in the study of vibrational phenomena, where the matrices  $M$ ,  $C$ ,  $G$  and  $K$  represent mass, damping, gyroscopic coupling and stiffness parameters, respectively. The stability of second-order systems is also important in feedback-control design. Linear feedback control of second-order systems leads to closed-loop systems that are also of second order. The closed-loop mass, damping and stiffness matrices can be modified by using acceleration, velocity, and position feedback, respectively. A part of the design problem is to choose the feedback gains such that the matrices  $M$ ,  $C$ ,  $G$  and  $K$  for the closed-loop system satisfy some stability criterion. In most applications and throughout this paper  $M$  is positive definite,  $C$  is nonnegative definite,  $G$  is skew symmetric and  $K$  is symmetric. Here, positive-definite and nonnegative-definite matrices are assumed to be symmetric.

The purpose of this paper is to provide a self-contained, unified and extended treatment of the stability of matrix second-order systems. The results we obtain encompass numerous results from the prior literature in addition to several new results. Specifically, in addition to obtaining necessary and sufficient conditions for Lyapunov and asymptotic stability, we consider the case of *semistability*, a concept first introduced in Campbell and Rose (1979). Semistability is of particular interest in the analysis of vibrating systems in that it represents the case of "damped rigid body modes," that is, systems that eventually come to rest, although not necessarily at a specified equilibrium point. This paper presents the first treatment of semistability for matrix second-order systems.

In prior work, Moran (1970) gave necessary and sufficient

conditions for the case in which  $K$  is positive definite. His condition, which is applicable in the presence of gyroscopic terms, can be stated as follows: *The second-order system is asymptotically stable if and only if no modal vector of the corresponding undamped system (that is, with  $C = 0$ ) lies in the nullspace of  $C$ .* This result follows from Lemma 2 of this work. Walker and Schmitendorf (1973) gave an algebraic condition for asymptotic stability, which is given by condition (32) in this work. Hughes and Gardner (1975) extended this result to include gyroscopic terms. All these works gave necessary and sufficient conditions for the system to be asymptotically stable with nonnegative-definite damping and positive-definite stiffness. Zajac (1965) coined the phrase "pervasive damping" to describe such systems. Roberson (1968) devised a constructive method for determining if a system is pervasively damped. Inman (1983) gave conditions for asymptotic stability when the damping and stiffness matrices are asymmetric but simultaneously symmetrizable. The necessary and sufficient condition given by him is an extension of condition (32) of this work.

Greenlee (1975) gave a necessary and sufficient geometric condition for Lyapunov stability when  $C = 0$ . Condition (29), with  $C = 0$ , can be shown to be the algebraic equivalent of Greenlee's condition. Connell (1969) gave a sufficient condition for asymptotic stability in the presence of gyroscopic terms when the damping is nonnegative definite. His condition is based on the Krasovskii-LaSalle theorem on asymptotic stability.

The literature also contains stability criteria involving less restrictive conditions on the coefficient matrices than those assumed in the paper. Probably the oldest among these is the Kelvin-Tait-Chetayev theorem (Chetayev, 1961) which was later made stronger by Zajac (1964). Zajac's theorem can be stated as follows: *If  $C$  is positive definite, then the number of open right half plane eigenvalues of the second-order system is equal to the number of negative eigenvalues of  $K$ .* Wimmer (1974) further extended this result to the case in which  $C$  is only nonnegative definite. Walker (1970) gave sufficient conditions for asymptotic stability for the general case in which

<sup>1</sup>This research is supported in part by the Air Force Office of Scientific Research under grant F49620-92-J-0127.

Contributed by the Design Engineering Division for publication in the *Special 50th Anniversary Design Issue*. Manuscript received Oct. 1994. Technical Editor: D. J. Inman.

neither  $C$  nor  $K$  satisfies symmetry or definiteness properties. His condition depends upon the existence of matrices having specified properties. Mingori (1970) gave a sufficient condition for asymptotic stability when the damping is positive definite, the stiffness is asymmetric and certain commutativity conditions are met. Mingori's result is a generalization of the Kelvin-Tait-Chataev theorem. Fawzy (1979) gave a necessary and sufficient condition based on Lyapunov's lemma. The same approach was adopted by Ahmadian and Inman (1985, 1986) to arrive at sufficient conditions for Lyapunov and asymptotic stability. Kliem and Pommer (1986) obtained a sufficient condition involving a lower bound on the magnitudes of the eigenvalues of the system. Shieh et al. (1987) obtained various sufficient conditions for stability and instability using Lyapunov theory.

The problem of gyroscopic stabilization, that is, Lyapunov stability with  $C = 0$ ,  $K$  not necessarily nonnegative definite and nonzero  $G$ , has also been studied. It will be shown that in this case, the system is Hamiltonian. One of the earliest results on this problem, which can be found in Chetayev (1961), can be stated as follows: *If the stiffness matrix  $K$  has an odd number of negative eigenvalues, then the gyroscopic system is unstable.* This result, along with related observations, is also stated in Greenwood (1977). A similar result holds for linear Hamiltonian systems in general (Bloch et al., 1994). Plaut (1976) gave alternative forms of the eigenvalue problem associated with gyroscopic systems. Hagedorn (1975) showed that a gyroscopic system is unstable if  $4K - GM^{-1}G$  is negative definite. In later work, Huseyin et al. (1983) showed that the system is Lyapunov stable if  $4K - GM^{-1}G$  is positive definite and  $GM^{-1}K - KM^{-1}G$  is positive semidefinite. The same paper also showed that if  $GM^{-1}K = KM^{-1}G$ , then the system is Lyapunov stable if and only if  $4K - GM^{-1}G$  is positive definite. Inman (1988) proposed a sufficient condition for Lyapunov stability when the stiffness is negative definite, but the proof given for this result was later shown to be erroneous (Walker, 1991) and counterexamples were provided by Barkwell and Lancaster (1992). Using Lyapunov theory, Walker (1991) obtained sufficient conditions in terms of the existence of scalars satisfying certain properties. A discussion of Walker (1991) by Ly (1992) includes a few sufficient conditions for instability and a sufficient condition for Lyapunov stability. Huseyin (1991) obtained a related sufficient condition for stability using an alternative approach. Barkwell and Lancaster (1992) arrived at a sufficient condition for Lyapunov stability using matrix pencil methods. Recently, Wu and Tsao (1994) obtained a sufficient condition for Lyapunov stability using a result from Huseyin (1978). The main results of Hagedorn (1975), Huseyin et al. (1983), Walker (1991) and Huseyin (1991) are rederived in this paper using a slightly different approach. A critical survey and comparison of various Lyapunov stability criteria for gyroscopic systems is given in Huseyin (1976, 1981, 1984) and Knoblauch and Inman (1994).

As mentioned earlier, stability criteria for second-order systems are also of interest in control design. Consider a second-order plant given by

$$M_P \ddot{x}_P + C_P \dot{x}_P + K_P x_P = B_P u_P, \\ y_P = C_{Pa} \ddot{x}_P + C_{Pv} \dot{x}_P + C_{Pp} x_P.$$

One can design a second-order compensator of the form

$$M_C \ddot{x}_C + C_C \dot{x}_C + K_C x_C = B_C y_P.$$

A control law of the form  $u_P = C_{Ca} \ddot{x}_C + C_{Cv} \dot{x}_C + C_{Cp} x_C + Lu_C$  gives a second-order closed-loop system with

$$M = \begin{bmatrix} M_P - B_P L C_{Pa} & -B_P C_{Ca} \\ -B_C C_{Pa} & M_C \end{bmatrix}, \\ C = \begin{bmatrix} C_P - B_P L C_{Pv} & -B_P C_{Cv} \\ -B_C C_{Pv} & C_C \end{bmatrix}, \\ K = \begin{bmatrix} K_P - B_P L C_{Pp} & -B_P C_{Cp} \\ -B_C C_{Pp} & K_C \end{bmatrix}.$$

To guarantee asymptotic stability of the closed-loop system, the compensator parameters as well as the matrices  $C_{Ca}$ ,  $C_{Cv}$ ,  $C_{Cp}$  and  $L$  can be chosen such that  $M$ ,  $C$  and  $K$  satisfy a stability criterion. This is the idea behind many static and dynamic feedback designs in recent literature (Gardiner, 1992; Juang and Phan, 1992; Morris and Juang, 1994). An added advantage of controllers obtained in this way is that such controllers are often model-independent and therefore, the closed-loop properties which result are relatively insensitive to plant uncertainties (Juang and Phan, 1992).

## 2 Preliminaries

We begin by defining three types of stability for the linear system

$$\dot{x}(t) = Ax(t), \quad (1)$$

where  $t \geq 0$ ,  $x(t) \in \mathbf{R}^n$  and  $A \in \mathbf{R}^{n \times n}$ .

**Definition 1.**  $A$  is *Lyapunov stable* if, for every initial condition  $x(0)$ , there exists  $\epsilon > 0$  such that  $\|x(t)\| < \epsilon$  for all  $t \geq 0$ .

**Definition 2.**  $A$  is *semistable* if  $\lim_{t \rightarrow \infty} x(t)$  exists for all initial conditions  $x(0)$ .

**Definition 3.**  $A$  is *asymptotically stable* if  $\lim_{t \rightarrow \infty} x(t) = 0$  for all initial conditions  $x(0)$ .

**Definition 4.**  $A$  is *unstable* if  $A$  is not Lyapunov stable.

We also recall that if  $\lambda \in \text{spec}(A)$ , then  $\lambda$  is *semisimple* (Kato, 1984) if every Jordan block of  $A$  associated with  $\lambda$  is

## Nomenclature

$\mathbf{R}(\mathbf{C})$  = real (complex) numbers  
 $\mathbf{R}^n(\mathbf{C}^n)$  = real (complex) vectors of dimension  $n$   
 $\mathbf{R}^{n \times n}(\mathbf{C}^{n \times n})$  = real (complex)  $n \times n$  matrices  
 $j = \sqrt{-1}$   
 $\text{Re}(\lambda)$  = real part of  $\lambda$   
 $\|\cdot\|$  = Euclidean norm on  $\mathbf{R}^n$   
 $\text{spec}(A)$  = spectrum of the matrix  $A$   
 $\text{rank } A$  = rank of the matrix  $A$   
 $\text{tr } A$  = trace of the matrix  $A$

$\det A$  = determinant of the matrix  $A$   
 $\mathbf{N}(A)$  = nullspace of the matrix  $A$   
 $A^T$  = transpose of the matrix  $A$   
 $\bar{A}$  = complex conjugate of the matrix  $A$   
 $A^*$  = complex conjugate transpose of the matrix  $A$   
 $A^{-*}$  = inverse of the complex conjugate transpose of the matrix  $A$

$A^\dagger$  = Moore-Penrose generalized inverse of the matrix  $A$   
 $A > (\geq) 0$  = symmetric positive (nonnegative) definite matrix  
 $A^{1/2}$  = positive-definite square root of the positive-definite matrix  $A$   
 $A^{-1/2}$  = inverse of  $A^{1/2}$   
 $\triangleq$  = equal by definition

of size one, that is, if the algebraic multiplicity of  $\lambda$  is equal to the geometric multiplicity of  $\lambda$ . Further, it can be seen that  $\lambda \in \text{spec}(A)$  is semisimple if and only if

$$\text{rank}(\lambda I - A) = \text{rank}(\lambda I - A)^2. \quad (2)$$

The following result, which follows from the structure of the matrix exponential of  $A$ , shows that the stability of  $A$  depends on its eigenstructure.

**Proposition 1.** The following statements are valid.

(i)  $A$  is Lyapunov stable if and only if every eigenvalue of  $A$  lies in the closed left half complex plane and every eigenvalue of  $A$  with zero real part is semisimple.

(ii)  $A$  is semistable if and only if  $A$  is Lyapunov stable and  $A$  has no nonzero imaginary eigenvalues.

(iii)  $A$  is asymptotically stable if and only if every eigenvalue of  $A$  lies in the open left half complex plane.

Consider the matrix second-order system

$$M\ddot{q} + (C + G)\dot{q} + Kq = 0, \quad (3)$$

where  $q \in \mathbf{R}^r$ ,  $M, C, G, K \in \mathbf{R}^{r \times r}$ ,  $M > 0$ ,  $C \geq 0$ ,  $K = K^T$  and  $G = -G^T$ . Such a system can be rewritten in first-order form (1) by defining

$$x \triangleq \begin{bmatrix} q \\ \dot{q} \end{bmatrix}, \quad A \triangleq \begin{bmatrix} 0 & I \\ -M^{-1}K & -M^{-1}(C + G) \end{bmatrix}.$$

### 3 Main Results

The following result is stated and proved by Gardiner (1992). Since the result is basic to our development, we reproduce the proof here for completeness.

**Lemma 1.** Suppose  $K \geq 0$ . If  $\lambda \in \text{spec}(A)$  then  $\text{Re}(\lambda) \leq 0$ . Furthermore, if  $C = 0$ , then  $\text{Re}(\lambda) = 0$ .

**Proof.** Let  $\lambda \in \text{spec}(A)$  and  $x = \begin{bmatrix} x_1 \\ x_2 \end{bmatrix} \in N(\lambda I - A)$ ,

where  $x_1, x_2 \in \mathbf{C}^r$  and  $x \neq 0$ . Then  $x_2 = \lambda x_1$ , and  $(M\lambda^2 + \lambda G + \lambda C + K)x_1 = 0$ . Consequently,  $x_1^*(M\lambda^2 + \lambda G + \lambda C + K)x_1 = 0$ . Thus  $\lambda$  satisfies

$$m\lambda^2 + (c + jg)\lambda + k = 0, \quad (4)$$

where  $m = x_1^* M x_1 > 0$ ,  $c = x_1^* C x_1 \geq 0$ ,  $g = -j x_1^* G x_1$  and  $k = x_1^* K x_1 \geq 0$ . Let  $\lambda_1 = \sigma_1 + j\omega_1$  and  $\lambda_2 = \sigma_2 + j\omega_2$  denote the roots of (4). It follows that  $\lambda_1 + \lambda_2 = -(c + jg)/m$  and  $\lambda_1 \lambda_2 = k/m$ . These equations lead to (i)  $\sigma_1 + \sigma_2 = -c/m \leq 0$ , (ii)  $\omega_1 + \omega_2 = -g/m$ , (iii)  $\sigma_1 \sigma_2 - \omega_1 \omega_2 = k/m \geq 0$  and (iv)  $\sigma_1 \omega_2 + \sigma_2 \omega_1 = 0$ . Now suppose  $\sigma_1 > 0$ . Then by (i)  $\sigma_2 < 0$  and, consequently, by (iii)  $\omega_1 \omega_2 < 0$ . This implies  $\omega_2/\omega_1 < 0$  and  $\sigma_2/\sigma_1 < 0$ , which violates (iv). Thus both  $\sigma_1$  and  $\sigma_2$  must be nonpositive.

Next suppose that  $c = 0$ . Then (i) implies  $\sigma_1 + \sigma_2 = 0$ . Since  $\sigma_1 \leq 0$  and  $\sigma_2 \leq 0$ , it follows that both  $\sigma_1$  and  $\sigma_2$  are zero.  $\square$

Before stating the next lemma, we define

$$A_0 \triangleq \begin{bmatrix} 0 & I \\ -M^{-1}K & -M^{-1}G \end{bmatrix}, \quad C_0 \triangleq [C \ 0].$$

Note that  $A_0$  represents the undamped gyroscopic system obtained from (3) by setting  $C = 0$ . The next lemma states that every oscillatory mode of  $A$  is also a mode of  $A_0$  that is unaffected by the damping. The proof is based on a technique used in the proof of Theorem 1 in Moran (1970).

**Lemma 2.** Let  $\omega \in \mathbf{R}$ ,  $\omega \neq 0$ . Then

$$N(j\omega I - A) = N \begin{bmatrix} j\omega I - A_0 \\ C_0 \end{bmatrix}. \quad (5)$$

**Proof.** Let  $x = \begin{bmatrix} x_1 \\ x_2 \end{bmatrix} \in N(j\omega I - A)$ , where  $x_1, x_2 \in \mathbf{C}^r$ .

Then  $x_2 = j\omega x_1$ , and  $(K - M\omega^2 + j\omega G + j\omega C)x_1 = 0$ . Consequently,  $x_1^*(K - M\omega^2 + j\omega G + j\omega C)x_1 = 0$ . Since  $K - M\omega^2 + j\omega G$  is Hermitian and  $j\omega C$  is skew Hermitian, it follows that  $x_1^*(K - M\omega^2 + j\omega G)x_1$  is real and  $x_1^*(j\omega C)x_1$  is imaginary. Hence  $x_1^*(K - M\omega^2 + j\omega G)x_1 = 0$  and  $x_1^*(j\omega C)x_1 = 0$ . Now, since  $C$  is nonnegative definite, it follows that  $Cx_1 = 0$  and thus  $(K - M\omega^2 + j\omega G)x_1 = 0$ . Combining these relations yield

$$\begin{bmatrix} j\omega I & -I \\ M^{-1}K & j\omega I + M^{-1}G \\ C & 0 \end{bmatrix} x = 0,$$

which is equivalent to

$$\begin{bmatrix} j\omega I - A_0 \\ C_0 \end{bmatrix} x = 0.$$

Conversely,  $\begin{bmatrix} j\omega I - A_0 \\ C_0 \end{bmatrix} x = 0$  implies  $(j\omega I - A)x = 0$ .  $\square$

The next lemma shows that if the stiffness matrix  $K$  is nonnegative definite, or  $G = 0$ , then every oscillatory mode is harmonic, that is, the system (3) possesses no divergent oscillatory modes.

**Lemma 3.** Suppose  $j\omega \in \text{spec}(A)$ , where  $\omega \neq 0$ . If either  $K \geq 0$  or  $G = 0$ , then  $j\omega$  is semisimple.

**Proof.** Since  $N(j\omega I - A) \subseteq N(j\omega I - A)^2$ , it suffices to show that  $N(j\omega I - A)^2 \subseteq N(j\omega I - A)$ . Let

$$y = \begin{bmatrix} y_1 \\ y_2 \end{bmatrix} = (j\omega I - A) \begin{bmatrix} x_1 \\ x_2 \end{bmatrix},$$

where  $y_1, y_2, x_1, x_2 \in \mathbf{C}^r$ . Then

$$y_1 = j\omega x_1 - x_2, \quad (6)$$

and

$$My_2 = Kx_1 + j\omega Mx_2 + (C + G)x_2. \quad (7)$$

Now, suppose that  $x = \begin{bmatrix} x_1 \\ x_2 \end{bmatrix} \in N(j\omega I - A)^2$  so that  $(j\omega I - A)y = (j\omega I - A)^2 x = 0$ . Then Lemma 2 implies that

$$\begin{bmatrix} j\omega I - A_0 \\ C_0 \end{bmatrix} y = 0,$$

which gives

$$y_2 = j\omega y_1, \quad (8)$$

$$Ky_1 + j\omega My_2 + Gy_2 = 0, \quad (9)$$

$$Cy_1 = 0. \quad (10)$$

Using (6) and (8) to eliminate  $y_2$  and  $x_2$  from (7) gives

$$2j\omega My_1 + Gy_1 = Kx_1 - \omega^2 Mx_1 + j\omega(C + G)x_1. \quad (11)$$

Eliminating  $y_2$  from (9) by using (8) gives

$$Ky_1 - \omega^2 My_1 + j\omega Gy_1 = 0. \quad (12)$$

Using Eqs. (11), (12) and (10), we compute

$$\begin{aligned} 2j\omega y_1^* My_1 + y_1^* Gy_1 &= y_1^* [Kx_1 - \omega^2 Mx_1 + j\omega(C + G)x_1] \\ &= x_1^* [Ky_1 - \omega^2 My_1 - j\omega(C - G)y_1] \\ &= 0. \end{aligned} \quad (13)$$

Also, from Eqs. (11) and (3), we have

$$\begin{aligned} y_1^* Ky_1 + \omega^2 y_1^* My_1 &= y_1^* (Ky_1 - \omega^2 My_1 + j\omega Gy_1) \\ &\quad - j\omega(2j\omega y_1^* My_1 + y_1^* Gy_1) = 0. \end{aligned} \quad (14)$$

Now, if  $K \geq 0$ , then, since  $\omega \neq 0$  and  $M > 0$ , it follows from (14) that  $y_1 = 0$ . On the other hand, if  $G = 0$ , then it follows from (13) that  $y_1 = 0$ . In either case,  $y_2 = J\omega y_1 = 0$  and hence  $y = (J\omega I - A)x = 0$ . Thus  $N(J\omega I - A)^2 \subseteq N(J\omega I - A)$ .  $\square$

If  $G$  is nonzero and  $K$  is not nonnegative definite, then nonzero imaginary eigenvalues of  $A$  may not be semisimple. This can be seen by taking  $M = I$ ,  $C = 0$ ,  $G = \begin{bmatrix} 0 & -2 \\ 2 & 0 \end{bmatrix}$  and  $K = -I$ . In this case, solutions of (3) involve terms of the form  $t \sin t$ . The next result gives a convenient characterization of the nullspaces of  $A$  and  $A^2$ .

**Lemma 4.**

$$N(A) = N \begin{bmatrix} K & 0 \\ 0 & I \end{bmatrix}, \quad N(A^2) = N \begin{bmatrix} K & G \\ 0 & K \\ 0 & C \end{bmatrix}. \quad (15)$$

**Proof.** Let  $x = \begin{bmatrix} x_1 \\ x_2 \end{bmatrix}$ , where  $x_1, x_2 \in \mathbb{C}^r$ . It can easily be shown that  $Ax = 0$  if and only if  $Kx_1 = 0$  and  $x_2 = 0$ , which proves the first equality.

Next, suppose that  $A^2x = 0$ , which implies

$$Kx_1 + (C + G)x_2 = 0 \quad (16)$$

and

$$(C + G)M^{-1}Kx_1 - Kx_2 + (C + G)M^{-1}(C + G)x_2 = 0. \quad (17)$$

Eliminating  $Kx_1$  in Eq. (17) leads to  $Kx_2 = 0$ . This along with (16) implies  $x_2^*Kx_1 = -x_2^*(C + G)x_2 = 0$ . Since  $x_2^*Cx_2$  and  $x_2^*Gx_2$  are the real and imaginary parts, respectively, of  $x_2^*(C + G)x_2$ , it follows that  $x_2^*Cx_2 = x_2^*Gx_2 = 0$ . Since  $C$  is nonnegative definite,  $x_2^*Cx_2 = 0$  implies  $Cx_2 = 0$ . This together with (16) gives  $Kx_1 + Gx_2 = 0$ . Thus

$$\begin{bmatrix} K & G \\ 0 & K \\ 0 & C \end{bmatrix} x = 0.$$

The converse is easily shown.  $\square$

The following lemma shows that if either the stiffness matrix  $K$  is nonnegative definite or the gyroscopic term  $G$  is zero, then every polynomially divergent mode of the system (3) is linearly divergent.

**Lemma 5.** If  $K \geq 0$  or  $G = 0$ , then

$$\text{rank } A^2 = \text{rank } A^3. \quad (18)$$

**Proof.** Since  $N(A^2) \subseteq N(A^3)$ , it suffices to show that  $N(A^3) \subseteq N(A^2)$ . Suppose  $x = \begin{bmatrix} x_1 \\ x_2 \end{bmatrix} \in N(A^3)$ , where  $x_1, x_2 \in \mathbb{C}^r$ . Then  $A^2Ax = 0$ . From Lemma 4 it follows that

$$\begin{bmatrix} K & G \\ 0 & K \\ 0 & C \end{bmatrix} \begin{bmatrix} 0 & I \\ -M^{-1}K & -M^{-1}(C + G) \end{bmatrix} \begin{bmatrix} x_1 \\ x_2 \end{bmatrix} = 0.$$

Hence

$$Ky = 0, \quad Cy = 0, \quad Gy - Kx_2 = 0, \quad (19)$$

where  $y = M^{-1}Kx_1 + M^{-1}(C + G)x_2$ . Equations (19) imply that

$$x_1^*Ky + x_2^*Cy - x_2^*(Gy - Kx_2) = 0, \quad (20)$$

which leads to

$$\begin{aligned} [Kx_1 + (C + G)x_2]^* M^{-1} [Kx_1 + (C + G)x_2] + x_2^* Kx_2 \\ = 0. \quad (21) \end{aligned}$$

If  $K$  is nonnegative definite, then, since  $M^{-1}$  is positive definite, it follows that

$$Kx_1 + (C + G)x_2 = 0, \quad (22)$$

and

$$Kx_2 = 0. \quad (23)$$

If  $G = 0$  then (19) yields (23), and (21) yields (22). Thus, in either case, it follows that

$$\begin{aligned} A^2x &= A \begin{bmatrix} 0 & I \\ -M^{-1}K & -M^{-1}(C + G) \end{bmatrix} \begin{bmatrix} x_1 \\ x_2 \end{bmatrix} \\ &= \begin{bmatrix} 0 & I \\ -M^{-1}K & -M^{-1}(C + G) \end{bmatrix} \begin{bmatrix} x_2 \\ 0 \end{bmatrix} = 0 \end{aligned}$$

as required.  $\square$

The following theorem gives our main result.

**Theorem 1.** Suppose  $K \geq 0$ . Then the following statements are valid.

(i)  $A$  is Lyapunov stable if and only if

$$\text{rank} \begin{bmatrix} K & G \\ 0 & K \\ 0 & C \end{bmatrix} = r + \text{rank } K. \quad (24)$$

(ii)  $A$  is semistable if and only if  $A$  is Lyapunov stable and

$$\text{rank} \begin{bmatrix} C_0 \\ C_0 A_0 \\ C_0 A_0^2 \\ \vdots \\ C_0 A_0^{2r-1} \end{bmatrix} = \text{rank} \begin{bmatrix} C_0 \\ A_0 \end{bmatrix}. \quad (25)$$

(iii)  $A$  is asymptotically stable if and only if  $A$  is semistable and  $K$  is positive definite.

**Proof.** (i) From Lemma 1, Lemma 3 and Proposition 1, it follows that  $A$  is Lyapunov stable if and only if the zero eigenvalue of  $A$  is semisimple. A necessary and sufficient condition for this to be true is  $\text{rank } A^2 = \text{rank } A$ , which, in view of Lemma 4, is equivalent to (24).

(ii)  $A$  is semistable if and only if  $A$  is Lyapunov stable and  $J\omega \notin \text{spec}(A)$  for all  $\omega \neq 0$ . It follows from Lemma 2 that the latter condition is equivalent to

$$\text{rank} \begin{bmatrix} J\omega I - A_0 \\ C_0 \end{bmatrix} = 2r, \quad \omega \neq 0. \quad (26)$$

To prove the sufficiency of condition (25) suppose that condition (26) is false, that is, there exists  $0 \neq x \in \mathbb{C}^{2r}$  and  $\omega \neq 0$  such that

$$\begin{bmatrix} J\omega I - A_0 \\ C_0 \end{bmatrix} x = 0.$$

This implies that  $A_0 x = J\omega x$  and  $C_0 x = 0$ . Consequently,  $A^i x = (J\omega)^i x$  and  $C_0 A^i x = 0$  for all positive integers  $i$ . Hence

$$\begin{bmatrix} C_0 \\ C_0 A_0 \\ C_0 A_0^2 \\ \vdots \\ C_0 A_0^{2r-1} \end{bmatrix} x = 0. \quad (27)$$

but  $\begin{bmatrix} C_0 \\ A_0 \end{bmatrix} x = \begin{bmatrix} 0 \\ J\omega x \end{bmatrix} \neq 0$ . This along with the fact that

$$N \begin{bmatrix} C_0 \\ A_0 \end{bmatrix} \subseteq N \begin{bmatrix} C_0 \\ C_0 A_0 \\ C_0 A_0^2 \\ \vdots \\ C_0 A_0^{2r-1} \end{bmatrix}, \quad (28)$$

shows that condition (25) is false, which proves sufficiency.

To prove the necessity of condition (25), suppose  $A$  is semistable so that condition (26) holds. Now, the nullspace of the matrix in (27) is the span of those eigenvectors of  $A_0$  that belong to the nullspace of  $C_0$ . But (26) along with the fact that  $A_0$  has only imaginary eigenvalues implies that those eigenvectors of  $A_0$  that belong to the nullspace of  $C_0$  correspond to the zero eigenvalue of  $A_0$ . Therefore, (27) implies  $\begin{bmatrix} C_0 \\ A_0 \end{bmatrix} x = 0$ . This, along with (28), proves the necessity.

(iii) From Lemma 4 it follows that  $0 \notin \text{spec}(A)$  if and only if  $\det K \neq 0$ , in which case, by Proposition 1, the semistability of  $A$  is equivalent to the absence of nonzero imaginary eigenvalues in  $\text{spec}(A)$ . Since Lemma 1 states that all the eigenvalues of  $A$  are located in the closed left half plane, the result follows.  $\square$

Condition (24) for Lyapunov stability can be restated as follows.

**Corollary 1.** Suppose  $K \geq 0$ . Then  $A$  is Lyapunov stable if and only if

$$\text{rank}[K + C + G^T(I - K^\dagger K)G] = r. \quad (29)$$

**Proof.** Since  $\text{rank } B = \text{rank } B^T B$  for every matrix  $B$ , condition (24) becomes

$$\text{rank} \begin{bmatrix} K^2 & KG \\ G^T K & K^2 + G^T G + C^2 \end{bmatrix} = r + \text{rank } K.$$

The matrix on the left hand side above can be shown to be equal to

$$\begin{bmatrix} I & 0 \\ G^T K(K^\dagger)^2 & I \end{bmatrix} \begin{bmatrix} K^2 & 0 \\ 0 & K^2 + C^2 + G^T(I - K^\dagger K)G \end{bmatrix} \begin{bmatrix} I & 0 \\ G^T K(K^\dagger)^2 & I \end{bmatrix}^T.$$

Since congruence preserves rank, the required condition becomes

$$\text{rank } K^2 + \text{rank}[K^2 + C^2 + G^T(I - K^\dagger K)G] = r + \text{rank } K.$$

Being symmetric,  $K$  satisfies  $\text{rank } K^2 = \text{rank } K$ . Hence (24) is equivalent to

$$\text{rank}[K^2 + C^2 + G^T(I - K^\dagger K)G] = r. \quad (30)$$

Now, suppose  $[K^2 + C^2 + G^T(I - K^\dagger K)G]x = 0$ . Since  $K^2$ ,  $C^2$  and  $G^T(I - K^\dagger K)G$  are nonnegative definite, premultiplying by  $x^*$  gives  $x^* K^2 x = 0$ ,  $x^* C^2 x = 0$  and  $x^* G^T(I - K^\dagger K)Gx = 0$ , which implies  $G^T(I - K^\dagger K)Gx = 0$ . Since  $K$  and  $C$  are symmetric, it follows that  $Kx = 0$  and  $Cx = 0$ . Thus  $[K + C + G^T(I - K^\dagger K)G]x = 0$ . The converse can be proved in a similar manner. Therefore,

$$\text{rank}[K^2 + C^2 + G^T(I - K^\dagger K)G]$$

$$= \text{rank}[K + C + G^T(I - K^\dagger K)G].$$

The result then follows from (30).  $\square$

The following result is the specialization of Theorem 1 to the case  $G = 0$ .

**Corollary 2.** Suppose  $K \geq 0$  and  $G = 0$ . Then the following statements are valid.

(i)  $A$  is Lyapunov stable if and only if

$$\text{rank} \begin{bmatrix} K \\ C \end{bmatrix} = r. \quad (31)$$

(ii)  $A$  is semistable if and only if

$$\text{rank} \begin{bmatrix} C \\ C(M^{-1}K) \\ C(M^{-1}K)^2 \\ \vdots \\ C(M^{-1}K)^{r-1} \end{bmatrix} = r. \quad (32)$$

**Proof.** (i) If  $G = 0$ , then  $\text{rank} \begin{bmatrix} K & G \\ 0 & K \\ 0 & C \end{bmatrix} = \text{rank } K + \text{rank} \begin{bmatrix} K \\ C \end{bmatrix}$ . The result then follows from (24).

(ii) It can easily be shown that, when  $G = 0$ , (25) reduces to

$$2\text{rank} \begin{bmatrix} C \\ C(M^{-1}K) \\ C(M^{-1}K)^2 \\ \vdots \\ C(M^{-1}K)^{r-1} \end{bmatrix} = r + \text{rank} \begin{bmatrix} C \\ M^{-1}K \end{bmatrix}. \quad (33)$$

To prove sufficiency, suppose condition (32) holds. Since

$$N \begin{bmatrix} C \\ M^{-1}K \end{bmatrix} \subseteq N \begin{bmatrix} C \\ C(M^{-1}K) \\ C(M^{-1}K)^2 \\ \vdots \\ C(M^{-1}K)^{r-1} \end{bmatrix},$$

and  $\text{rank} \begin{bmatrix} K \\ C \end{bmatrix} = \text{rank} \begin{bmatrix} C \\ M^{-1}K \end{bmatrix}$ , it follows that (31) is satisfied and  $A$  is Lyapunov stable. Thus (33) and hence (25) is satisfied and, by Theorem 1,  $A$  is semistable.

On the other hand, if  $A$  is semistable, then  $A$  is Lyapunov stable and (31) holds. Also by Theorem 1, (33) is true. The result then follows from (31) and (33).  $\square$

It should be noted that since  $K$  and  $C$  are nonnegative definite, condition (31) is equivalent to  $\text{rank}(C + K) = r$ . This condition also follows directly from (29) when  $G = 0$ .

#### 4 Gyroscopic Stabilization

This section deals with the stability properties of (3) when  $C = 0$ . Throughout this section, we thus use  $A$  to denote the matrix  $A_0$  defined earlier. The following result, which does not require that  $K$  be nonnegative definite, gives a useful property of undamped gyroscopic systems. For this result we define

$$\tilde{A} \triangleq \begin{bmatrix} -\frac{1}{2}M^{-1/2}GM^{-1/2} & I \\ -M^{-1/2}(K - \frac{1}{4}GM^{-1}G)M^{-1/2} & -\frac{1}{2}M^{-1/2}GM^{-1/2} \end{bmatrix}.$$

**Proposition 2.**  $A$  is similar to the Hamiltonian matrix  $\tilde{A}$ .

**Proof.** First note the similarity transformation

$$A = \begin{bmatrix} M^{-1/2} & 0 \\ -\frac{1}{2}M^{-1}GM^{-1/2} & M^{-1/2} \end{bmatrix}$$

$$\tilde{A} = \begin{bmatrix} M^{-1/2} & 0 \\ -\frac{1}{2}M^{-1}GM^{-1/2} & M^{-1/2} \end{bmatrix}^{-1}$$

Since  $J\tilde{A} = (J\tilde{A})^T$ , where  $J = \begin{bmatrix} 0 & I \\ -I & 0 \end{bmatrix}$ , it follows that  $\tilde{A}$  is Hamiltonian.  $\square$

From the properties of Hamiltonian matrices (Laub and Meyer, 1974), it follows that  $\text{spec}(A) = -\text{spec}(A)$ . Thus the eigenvalues of  $A$  form symmetric pairs about the origin. Hence a gyroscopic system without viscous damping (that is, with  $C = 0$ ) cannot be asymptotically stable. Also, in this case,  $A$  is semistable if and only if all the eigenvalues of  $A$  are zero and semisimple, that is, if and only if  $A = 0$ . Since, by definition,  $A$  is nonzero, it follows that  $A$  also cannot be semistable.

The following result gives a condition for the Lyapunov stability of a linear Hamiltonian system. For this result and the next, the matrix  $A$  need only satisfy the stated assumptions.

**Theorem 2.** Suppose  $A \in \mathbf{R}^{2r \times 2r}$  is similar to a Hamiltonian matrix. Then  $A$  is Lyapunov stable if and only if there exists a positive-definite matrix  $P \in \mathbf{R}^{2r \times 2r}$  such that

$$A^T P + PA = 0. \quad (34)$$

**Proof.** If  $A$  is similar to a Hamiltonian matrix, then  $\text{spec}(A) = -\text{spec}(A)$ . It then follows that  $A$  is Lyapunov stable if and only if all the eigenvalues of  $A$  are imaginary and semisimple. Thus if  $A$  is Lyapunov stable, then it is diagonalizable by a similarity transformation and the diagonal form of  $A$  is skew Hermitian. On the other hand, if  $A$  is similar to a skew-Hermitian matrix, then it is Lyapunov stable. Hence  $A$  is Lyapunov stable if and only if there exists an invertible matrix  $S \in \mathbf{C}^{2r \times 2r}$  such that  $SAS^{-1} = -S^{-*}A^T S^*$ . This condition can be rewritten as

$$A^T S^* S + S^* S A = 0. \quad (35)$$

If  $S$  satisfies (35), then  $P = S^* S + S^T \bar{S}$  satisfies (34). On the other hand, if  $P$  satisfies (34), then  $S = P^{1/2}$  satisfies (35). This proves the result.  $\square$

It is worthwhile to point out that if  $P$  satisfies (34), then  $x^T P x$  is an integral of motion of (3). Thus the above theorem states that a linear Hamiltonian system such as an undamped gyroscopic system is Lyapunov stable if and only if there exists a constant of motion that is a quadratic positive-definite function of the states. Note that the sufficiency part of Theorem 2 also follows immediately from Lyapunov stability theory.

The following theorem gives a necessary and sufficient condition for instability.

**Theorem 3.** Suppose  $A \in \mathbf{R}^{2r \times 2r}$  is similar to a Hamiltonian matrix. Then  $A$  is unstable if and only if there exists a matrix  $Q = Q^T \in \mathbf{R}^{2r \times 2r}$  such that

$$0 \neq AQ + QA^T \leq 0. \quad (36)$$

**Proof.** Suppose there exists a real symmetric matrix  $Q$  that satisfies (36). Let  $V = -(AQ + QA^T)$ . If  $A$  is Lyapunov stable, then from Theorem 2 it follows that there exists a positive-definite matrix  $P$  satisfying (34). We compute  $\text{tr}$

$PV = -\text{tr } P(AQ + QA^T) = -\text{tr } (PAQ + QA^T P) = -\text{tr } Q(A^T P + PA) = 0$ . On the other hand, since  $V \geq 0$ ,  $V \neq 0$  and  $P > 0$ , it follows that  $\text{tr } PV > 0$ . This contradiction establishes the sufficiency.

Now, suppose that  $A$  is unstable. Then at least one of the following two cases must arise.

(i) There exists nonzero  $x \in \mathbf{C}^{2r}$  and  $\lambda \in \mathbf{C}$  such that  $Ax = \lambda x$  and  $\text{Re}(\lambda) < 0$ . Let  $\lambda = \sigma + j\omega$  and  $x = x_R + jx_I$ , where  $\sigma, \omega \in \mathbf{R}$  and  $x_R, x_I \in \mathbf{R}^{2r}$ . Then  $\sigma < 0$ ,  $Ax_R = \sigma x_R - \omega x_I$  and  $Ax_I = \sigma x_I + \omega x_R$ . Letting  $Q = x_R x_R^T + x_I x_I^T$ , it follows that  $AQ + QA^T = 2\sigma Q \leq 0$ .

(ii) There exists nonzero  $y \in \mathbf{C}^{2r}$  and  $\omega \in \mathbf{R}$  such that  $(j\omega I - A)^2 y = 0$  and  $(j\omega I - A)y = x \neq 0$ . Let  $y = y_R + jy_I$  and  $x = x_R + jx_I$ , where  $y_R, y_I, x_R, x_I \in \mathbf{R}^{2r}$ . Then  $Ax_R = -\omega x_I$ ,  $Ax_I = \omega x_R$ ,  $x_R = Ay_R + \omega y_I$  and  $x_I = Ay_I - \omega y_R$ . Now, letting  $Q = -(y_R x_R^T + x_R y_R^T + y_I x_I^T + x_I y_I^T)$ , we get  $AQ + QA^T = -2(x_R x_R^T + x_I x_I^T) \leq 0$ .  $\square$

Theorems 2 and 3 above, can be used to derive various stability and instability criteria for gyroscopic systems, as the following propositions illustrate. Note that the substitution  $q = M^{-1/2} q'$  can be used to transform (3) to a form in which the mass matrix  $M$  is replaced by the identity matrix and the stiffness matrix and the gyroscopic term are symmetric and skew symmetric, respectively. Hence, in the following propositions we assume without loss of generality that  $M = I$ .

**Proposition 3.** Suppose  $M = I$ . Then the following are sufficient for the Lyapunov stability of  $A$ .

(i)  $GK = KG$ ,  $K + \frac{1}{4}GG^T > 0$ .

(ii)  $K + G^T(I - K^+K)G > 0$ .

(iii) There exists a scalar  $\epsilon$  such that

$$K^2 > \epsilon K,$$

$$K + GG^T > \epsilon I + GK(K^2 - \epsilon K)^{-1}KG^T.$$

(iv) There exists a scalar  $\epsilon$  such that

$$K + GG^T > \epsilon I,$$

$$K^2 > \epsilon K + KG(K + GG^T - \epsilon I)^{-1}G^T K.$$

(v)  $K$  is nonsingular and there exists a scalar  $\epsilon$  such that

$$K^2 > \epsilon K,$$

$$K > \epsilon I + \epsilon G(K - \epsilon I)^{-1}G^T.$$

(vi)  $K$  is nonsingular and there exists a scalar  $\epsilon$  such that

$$K^{-1} > \epsilon I,$$

$$I + G^T K^{-1} G + G(K - \epsilon K^2)^{-1} G^T > \epsilon K$$

**Proof.** The conditions given above are proved by showing the existence of a real positive-definite matrix that satisfies (34). Note that the partitioned real symmetric matrix

$$P = \begin{bmatrix} P_1 & P_{12} \\ P_{12}^T & P_2 \end{bmatrix}$$

is positive definite if and only if the matrices  $P_1$  and  $P_2 - P_{12}^T P_1^{-1} P_{12}$  are both positive definite or if and only if the matrices  $P_2$  and  $P_1 - P_{12} P_2^{-1} P_{12}^T$  are both positive definite (Horn and Johnson, 1985).

(i) If  $K + \frac{1}{4}GG^T > 0$ , then

$$P = \begin{bmatrix} I & 0 \\ 0 & (K + \frac{1}{4}GG^T)^{-1} \end{bmatrix}$$

is positive definite. If  $GK = KG$ , then  $P$  satisfies  $\tilde{A}^T P + P\tilde{A} = 0$ .

(ii) It can be easily verified that

$$P = \begin{bmatrix} 2K + G^T(I - K^+K)G & G^T(I - K^+K) \\ (I - K^+K)G & 3I - K^+K \end{bmatrix}$$

satisfies (34) and is positive definite if  $K + G^T(I - K^+K)G > 0$ .

(iii), (iv) Equation (34) is satisfied by

$$P = \begin{bmatrix} K^2 - \epsilon K & KG \\ G^TK & K + GG^T - \epsilon I \end{bmatrix}.$$

$P$  is positive definite if either the conditions given in (iii) or those given in (iv) are satisfied.

(v) The matrix

$$P = \begin{bmatrix} I & G^T \\ 0 & I \end{bmatrix} \begin{bmatrix} K + GG^T - \epsilon I & G \\ G^T & I - \epsilon K^{-1} \end{bmatrix} \begin{bmatrix} I & 0 \\ G & I \end{bmatrix}$$

satisfies (34) and is positive definite if the given conditions are satisfied.

(vi) It can be easily verified that

$$P = \begin{bmatrix} I + G^TK^{-1}G - \epsilon K & G^TK^{-1} \\ K^{-1}G & K^{-1} - \epsilon I \end{bmatrix}$$

satisfies  $A^TP + PA = 0$  and is positive definite if the given conditions hold.  $\square$

The stability criteria (i) and (v) from Proposition 3 appear in Huseyin et al. (1983) and Walker (1991), respectively, while (iii) and (iv), which are equivalent, appear in Huseyin (1991). Conditions (ii) and (vi) are new.

**Remark.** Since  $\tilde{A}$  is Hamiltonian, the matrices  $(\tilde{A}^{-T})^{2m}J\tilde{A}^{2n+1}$  and  $(\tilde{A}^T)^{2m}J(\tilde{A}^{-1})^{2n+1}$  are symmetric and satisfy  $\tilde{A}^TP + P\tilde{A} = 0$ , for  $m, n = 0, 1, 2, \dots$ . Hence new stability criteria can be obtained by requiring that some linear combination of these matrices be positive definite. For instance, condition (vi) in the above proposition was obtained by choosing  $P = S^T(J\tilde{A} + \epsilon J\tilde{A}^{-1})S$ , where  $\tilde{A} = SAS^{-1}$ .

**Proposition 4.** Suppose  $M = I$ . Then the following are sufficient conditions for  $A$  to be unstable.

(i) There exists a scalar  $\epsilon$  such that

$$I > \epsilon K, \\ 4K(I - \epsilon K)^{-1} + G^T(I - \epsilon K)^{-1}G \leq 0.$$

(ii) There exists a scalar  $\epsilon$  such that

$$I > \epsilon K, \\ 4K(I - \epsilon K) + G^T(I - \epsilon K)G \leq 0.$$

(iii)  $K + \frac{1}{4}GG^T \leq 0$ .

**Proof.** (i) If  $Q = \begin{bmatrix} 0 & -(I - \epsilon K) \\ -(I - \epsilon K) & \epsilon(KG - GK) \end{bmatrix}$ , then

$AQ + QA^T$

$$= \begin{bmatrix} I & 0 \\ G^T & I \end{bmatrix} \begin{bmatrix} -2(I - \epsilon K) & G(I - \epsilon K) \\ (I - \epsilon K)G^T & 2K(I - \epsilon K) \end{bmatrix} \begin{bmatrix} I & G \\ 0 & I \end{bmatrix}$$

which is negative semidefinite if the given conditions are satisfied.

(ii) If  $Q = \begin{bmatrix} 0 & -(I - \epsilon K) \\ -(I - \epsilon K) & 0 \end{bmatrix}$ , then

$$AQ + QA^T = \begin{bmatrix} -2(I - \epsilon K) & (I - \epsilon K)G^T \\ G(I - \epsilon K) & 2K(I - \epsilon K) \end{bmatrix}.$$

It can be easily verified that  $AQ + QA^T$  is negative semidefinite if the given conditions are satisfied.

(iii) If  $K + \frac{1}{4}GG^T \leq 0$ , then condition (ii) of this proposition is satisfied with  $\epsilon = 0$ .  $\square$

Conditions (i) and (iii) from Proposition 4 are improved versions of the instability criteria obtained by Walker (1991) and Hagedorn (1975), respectively, while condition (ii) is new.

## 5 Examples

In this section we present several examples to illustrate the results.

**Example 1.** Consider  $C = K = \begin{bmatrix} 1 & 0 & 0 \\ 0 & 0 & 0 \\ 0 & 0 & 0 \end{bmatrix}$ . From Lemma

4, it follows that the zero eigenvalue of  $A$  has geometric multiplicity 2. For  $G = 0$ , it can easily be verified that  $\text{rank} \begin{bmatrix} K & G \\ 0 & K \\ 0 & C \end{bmatrix} = 2$  so that condition (24) is not satisfied. Also  $A$  has eigenvalues  $-0.5 \pm 0.866j, 0, 0, 0$  and  $0$ . Since the zero eigenvalue has algebraic multiplicity 4,  $A$  is not Lyapunov stable. This illustrates the necessity of (24).

For  $G = \begin{bmatrix} 0 & -1 & 1 \\ 1 & 0 & 1 \\ -1 & -1 & 0 \end{bmatrix}$ , (24) is satisfied. Furthermore,

$A$  has eigenvalues  $-0.39 \pm 1.84j, -0.11 \pm 0.52j, 0$  and  $0$ . Since the algebraic and geometric multiplicities of  $0 \in \text{spec}(A)$  are equal,  $A$  is Lyapunov stable. This illustrates gyroscopic stabilization as well as the sufficiency of (24).

**Example 2.** Consider  $C = \begin{bmatrix} 0 & 0 \\ 0 & 1 \end{bmatrix}$  and  $K = \begin{bmatrix} 1 & 0 \\ 0 & 0 \end{bmatrix}$ . For

$G = 0$ ,  $\text{rank} \begin{bmatrix} C_0 \\ C_0A_0 \\ C_0A_0^2 \\ C_0A_0^3 \end{bmatrix} = 2$  whereas  $\text{rank} \begin{bmatrix} C_0 \\ A_0 \end{bmatrix} = 4$  so that

(25) is not satisfied. At the same time  $A$  has eigenvalues  $\pm j, 0$  and  $-1$ .  $A$  is thus Lyapunov stable but not semistable. This illustrates the necessity of (25).

On the other hand, if  $G = \begin{bmatrix} 0 & 1 \\ -1 & 0 \end{bmatrix}$ , then (25) is satisfied and  $A$  eigenvalues  $-0.21 \pm 1.31j, -0.57$  and  $0$ . Thus  $A$  is semistable but not asymptotically stable. This illustrates the sufficiency of (25).

**Example 3.** In Example 2 above, if  $K = I$  with  $G = \begin{bmatrix} 0 & 1 \\ -1 & 0 \end{bmatrix}$ , then  $A$  has eigenvalues  $-0.35 \pm 1.5j$  and  $-0.15 \pm 0.63j$ .  $A$  is thus asymptotically stable while the conditions of Theorem 1 are satisfied.

The following example illustrates Lyapunov stability, semistability and asymptotic stability of a lumped-parameter system.

**Example 4.** Figure 1 shows a lumped-parameter system consisting of two masses having mass  $m_1$  and  $m_2$  and displacements  $q_1$  and  $q_2$ , respectively, linear springs with spring constants  $k_1$  and  $k_2$  and linear viscous dampers with damping coefficients  $c_1$  and  $c_2$ . The equations of motion for this system can be written in the form (3) with

$$M = \begin{bmatrix} m_1 & 0 \\ 0 & m_2 \end{bmatrix}, \quad C = \begin{bmatrix} c_1 + c_2 & -c_2 \\ -c_2 & c_2 \end{bmatrix}, \quad K = \begin{bmatrix} k_1 & 0 \\ 0 & k_2 \end{bmatrix}.$$

For different combinations of values of parameters, this system exhibits Lyapunov stability, semistability and asymptotic stability.

If  $m_1 = m_2, k_1 = k_2 > 0, c_1 = 0$  and  $c_2 > 0$ , then for

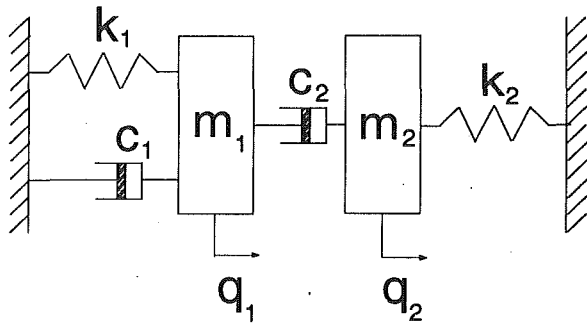

Fig. 1 A lumped-parameter system

certain initial conditions the two masses can oscillate at the same frequency with identical amplitudes and phases, so that the damper  $c_2$  dissipates no energy. Only relative motion between the masses, if present, is damped out. The system is thus Lyapunov stable but not semistable. It is easy to verify that in this case condition (31) in Corollary 2 is satisfied while the condition (32) for semistability is not satisfied.

If  $k_1 = 0$  and  $m_1, m_2, c_1, c_2$  and  $k_2$  are all positive, then every configuration in which the spring  $k_2$  is unstretched and the two masses are at rest is an equilibrium state. Thus both masses asymptotically approach a state of rest but the final position of the mass  $m_1$  depends on the initial velocity of  $m_1$ . In this case the system is semistable but not asymptotically stable. This is consistent with the results obtained since condition (32) for semistability is satisfied whereas part (iii) of Theorem 1 is not.

Finally, if all of the quantities  $m_1, m_2, c_1, c_2, k_1$  and  $k_2$  are positive, then both masses have unique equilibrium positions and all motions lead to dissipation of energy. Both masses asymptotically approach a state of rest at their respective equilibrium positions and the system is asymptotically stable. In this case,  $K$  is positive definite and condition (32) for semistability is satisfied. Thus, by Theorem 1, the system is asymptotically stable.

**Example 5.** Consider  $M = I, C = 0, G = \begin{bmatrix} 0 & -4 \\ 4 & 0 \end{bmatrix}$  and  $K = \begin{bmatrix} k_1 & 0 \\ 0 & k_2 \end{bmatrix}$ . This example has been used to test and compare various stability criteria for conservative gyroscopic systems (Walker, 1991; Knoblauch and Inman, 1994). It can be shown by direct analysis that  $k_1 k_2 > 0$  and  $k_1 + k_2 + 16 > 2\sqrt{k_1 k_2}$  are sufficient conditions for stability (Walker, 1991). However, these conditions are not necessary as claimed in Walker (1991). For instance, if  $k_1 = k_2 = 0$ , then (i) in Proposition 3 guarantees stability. We will apply the new condition (vi) from Proposition 3 to this example.

The first part of (vi) in Proposition 3 can be applied only if  $\det K = k_1 k_2 \neq 0$ . It follows from (vi) that  $A$  is Lyapunov stable if there exists a scalar  $\epsilon$  such that

$$\frac{1}{k_i}(1 - \epsilon k_i) > 0, \quad i = 1, 2, \quad (37)$$

$$1 - \epsilon k_1 - \frac{16\epsilon}{(1 - \epsilon k_2)} > 0, \quad (38)$$

$$1 - \epsilon k_2 - \frac{16\epsilon}{(1 - \epsilon k_1)} > 0. \quad (39)$$

If  $k_1 > 0$  and  $k_2 > 0$ , these conditions are satisfied with  $\epsilon = 0$ . If  $k_1 k_2 < 0$ , then the above conditions lead to  $0 < (1 - \epsilon k_1)(1 - \epsilon k_2) - 16\epsilon < 0$ , which is a contradiction. If  $k_1$

$< 0$  and  $k_2 < 0$ , then the above conditions lead to  $1 - \epsilon(k_1 + k_2 + 16) + \epsilon^2 k_1 k_2 < 0$ . A solution of this inequality exists if and only if  $k_1 + k_2 + 16 > 2\sqrt{k_1 k_2}$ . Note that this inequality is automatically satisfied if  $k_1 > 0$  and  $k_2 > 0$ . Thus, Proposition 3 implies that if  $k_1 k_2 > 0$  and  $k_1 + k_2 + 16 > 2\sqrt{k_1 k_2}$ , then  $A$  is Lyapunov stable. Conditions (iii), (iv) and (v) in Proposition 3 give the same sufficient conditions for stability (Knoblauch and Inman, 1994).

## Acknowledgment

We wish to thank Steve Campbell for helpful discussions, and Dan Inman for providing us with a copy of Knoblauch and Inman (1994).

## References

- Ahmadian, M., and Inman, D. J., 1985, "On the Stability of General Dynamic Systems Using a Liapunov's Direct Method Approach," *Computers & Structures*, Vol. 20, pp. 287-292.
- Ahmadian, M., and Inman, D. J., 1986, "Some Stability Results for General Linear Lumped-Parameter Systems," *ASME Journal of Applied Mechanics*, Vol. 53, pp. 10-14.
- Barkwell, L., and Lancaster, P., 1992, "Overdamped and Gyroscopic Vibrating Systems," *ASME Journal of Applied Mechanics*, Vol. 59, pp. 176-181.
- Bloch, A. M., Krishnaprasad, P. S., Marsden, J. E., and Ratiu, T. S., 1994, "Dissipation Induced Instabilities," *Annales de l'Institut Henri Poincaré*, Vol. 11, pp. 37-90.
- Campbell, S. L., and Rose, N. J., 1979, "Singular Perturbation of Autonomous Linear Systems," *SIAM Journal of Math. Analysis*, Vol. 10, pp. 542-551.
- Chetayev, N. G., 1961, *The Stability of Motion*, Pergamon Press, New York, pp. 95-100.
- Connell, G. M., 1969, "Asymptotic Stability of Second-Order Linear Systems with Semidefinite Damping," *AIAA Journal*, Vol. 7, pp. 1185-1187.
- Duffin, R. J., 1955, "A Minimax Theory for Overdamped Networks," *Journal of Rational Mechanics and Analysis*, Vol. 4, pp. 221-233.
- Fawzy, I., 1979, "A Simplified Stability Criterion for Nonconservative Systems," *ASME Journal of Applied Mechanics*, Vol. 46, pp. 423-426.
- Gardiner, J. D., 1992, "Stabilizing Control for Second Order Models and Positive Real Systems," *Journal of Guidance*, Vol. 15, pp. 280-282.
- Greenlee, W. M., 1975, "Lyapunov Stability of Linear Gyroscopic Systems," *Utilitas Mathematica*, Vol. 8, pp. 225-231.
- Greenwood, D. T., 1977, *Classical Dynamics*, Prentice Hall, Englewood Cliffs, N.J., pp. 127-129.
- Hagedorn, P., 1975, "Über die Instabilität konservativer Systeme mit gyroscopischen Kräften," *Archive for Rational Mechanics and Analysis*, Vol. 58, pp. 1-9.
- Horn, R. A., and Johnson, C. R., 1985, *Matrix Analysis*, Cambridge University Press, New York, p. 472.
- Hughes, P. C., and Gardner, L. T., 1975, "Asymptotic Stability of Linear Stationary Systems," *ASME Journal of Applied Mechanics*, Vol. 42, pp. 228-229.
- Huseyin, K., 1976, "Vibrations and Stability of Mechanical Systems," *Shock and Vibration Digest*, Vol. 8, No. 4, pp. 56-66.
- Huseyin, K., 1978, *Vibrations and Stability of Multiple Parameter Systems*, Sijthoff and Nordhoff, Alphen, p. 115.
- Huseyin, K., 1981, "Vibrations and Stability of Mechanical Systems: II," *Shock and Vibration Digest*, Vol. 13, No. 1, pp. 21-29.
- Huseyin, K., Hagedorn, P., and Teschner, W., 1983, "On the Stability of Linear Conservative Gyroscopic Systems," *Journal of Applied Mathematics and Physics*, Vol. 34, pp. 807-815.
- Huseyin, K., 1984, "Vibrations and Stability of Mechanical Systems: III," *Shock and Vibration Digest*, Vol. 16, No. 7, pp. 15-22.
- Huseyin, K., 1991, "On the Stability Criteria for Conservative Gyroscopic Systems," *ASME Journal of Vibration and Acoustics*, Vol. 113, pp. 58-61.
- Inman, D. J., 1983, "Dynamics of Asymmetric Nonconservative Systems," *ASME Journal of Applied Mechanics*, Vol. 50, pp. 199-203.
- Inman, D. J., 1988, "A Sufficient Condition for the Stability of Conservative Gyroscopic Systems," *ASME Journal of Applied Mechanics*, Vol. 55, pp. 895-898.
- Juang, J.-N., and Phan, M., 1992, "Robust Controller Designs for Second-Order Dynamic Systems: A Virtual Passive Approach," *Journal of Guidance, Control, and Dynamics*, Vol. 15, pp. 1192-1198.
- Kato, T., 1984, *Perturbation Theory for Linear Operators*, Springer Verlag, New York, pp. 41-43.
- Kliem, W., and Pommer, C., 1986, "On the Stability of Linear Nonconservative Systems," *Quarterly of Applied Mathematics*, Vol. 43, pp. 457-461.
- Knoblauch, J., and Inman, D. J., "On Stability Conditions for Conservative Gyroscopic Systems," preprint.



- Lancaster, P., 1966, *Lambda Matrices and Vibrating Systems*, Pergamon Press, New York, pp. 116–142.
- Laub, A. J., and Meyer, K., 1974, "Canonical Forms for Symplectic and Hamiltonian Matrices," *Celestial Mechanics*, Vol. 9, pp. 213–238.
- Ly, B. L., 1992, "Stability of Linear Conservative Gyroscopic Systems," *ASME Journal of Applied Mechanics*, Vol. 59, pp. 236–237.
- Mingori, D. L., 1970, "A Stability Theorem for Mechanical Systems With Constraint Damping," *ASME Journal of Applied Mechanics*, Vol. 37, pp. 253–257.
- Moran, T. J., 1970, "A Simple Alternative to the Routh-Hurwitz Criterion for Symmetric Systems," *ASME Journal of Applied Mechanics*, Vol. 37, pp. 1168–1170.
- Morris, K. A., and Juang, J.-N., 1994, "Dissipative Controller Designs for Second-Order Dynamic Systems," *IEEE Transactions on Automatic Control*, Vol. 39, pp. 1056–1063.
- Plaut, R. H., 1976, "Alternative Formulations for Discrete Gyroscopic Eigenvalue Problems," *AIAA Journal*, Vol. 14, pp. 431–435.
- Roberson, R. E., 1968, "Notes on the Thomson-Tait-Chetaev Stability Theorem," *The Journal of the Astronautical Sciences*, Vol. 15, pp. 319–324.
- Shieh, L. S., Mehio, M. M., and Dib, H. M., 1987, "Stability of the Second Order Matrix Polynomial," *IEEE Transactions on Automatic Control*, Vol. AC-32, pp. 231–233.
- Walker, J. A., 1970, "On the Stability of Linear Discrete Dynamic Systems," *ASME Journal of Applied Mechanics*, Vol. 37, pp. 271–275.
- Walker, J. A., and Schmitendorf, W. E., 1973, "A Simple Test for Asymptotic Stability in Partially Dissipative Symmetric Systems," *ASME Journal of Applied Mechanics*, Vol. 40, pp. 1120–1121.
- Walker, J. A., 1991, "Stability of Linear Conservative Gyroscopic Systems," *ASME Journal of Applied Mechanics*, Vol. 58, pp. 229–232.
- Wimmer, H. K., 1974, "Inertia Theorems for Matrices, Controllability, and Linear Vibrations," *Linear Algebra and its Applications*, Vol. 8, pp. 337–343.
- Wu, J.-W., and Tsao, T.-C., 1994, "A Sufficient Condition for Linear Conservative Gyroscopic Systems," *ASME Journal of Applied Mechanics*, Vol. 61, pp. 715–717.
- Zajac, E. E., 1964, "The Kelvin-Tait-Chetaev Theorem and Further Extensions," *The Journal of the Astronautical Sciences*, Vol. 11, pp. 46–49.
- Zajac, E. E., 1965, "Comments on 'Stability of Damped Mechanical Systems' and a Further Extension," *AIAA Journal*, Vol. 3, pp. 1794–1750.